

# **BURCHLAND XTS** Weed Barrier Plow

[www.Burchlandmfg.com](http://www.Burchlandmfg.com)

- Install Fabric Mulch
- Organic weed control
- Lasts for years
- Reduce labor
- Increase yields
- Install around established plants.

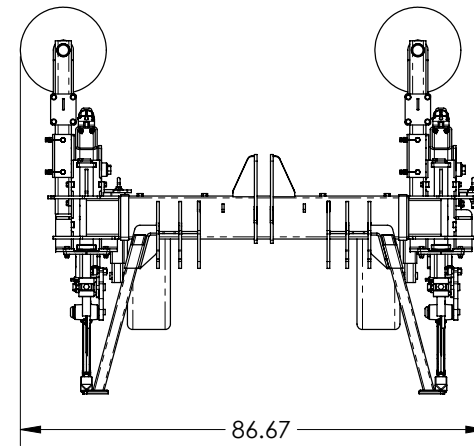

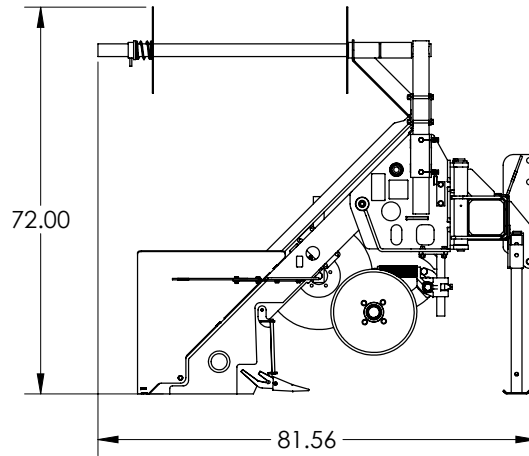
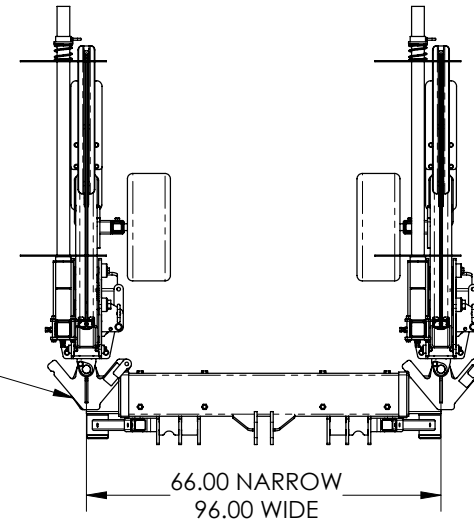
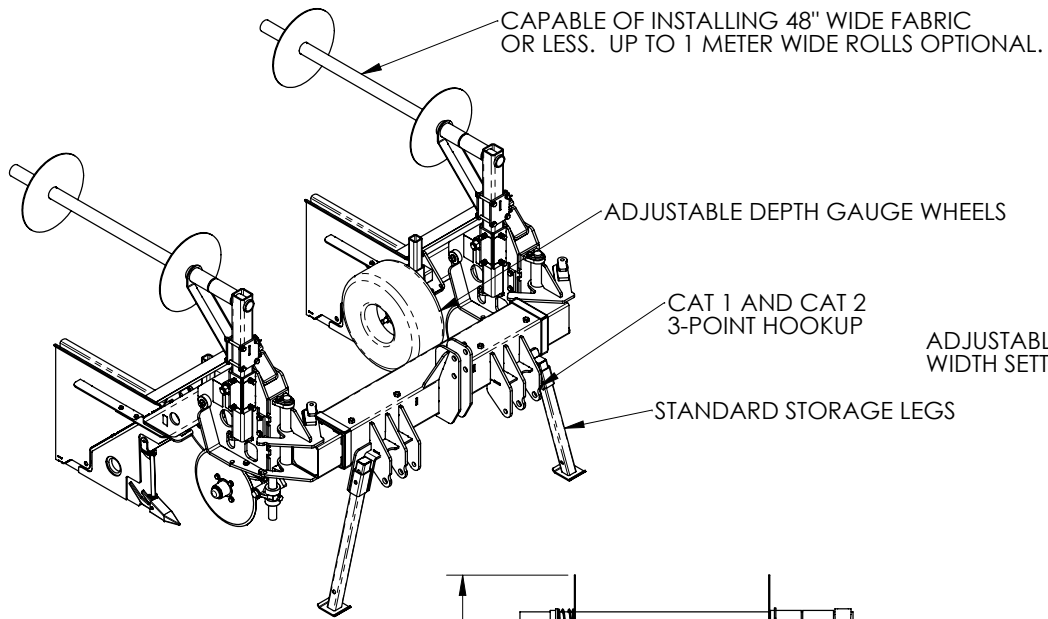

WEIGHT: 1750 LBS.  
CUSTOM WIDTHS AND SIZES AVAILABLE  
UPON REQUEST.

					3RD ANGLE PROJECTION	B	PAGE OF	REQD	ITEM NUMBER / MATERIAL	MATERIAL DESCRIPTION	LET
					UNLESS OTHERWISE SPEC. DIMNS. IN INCHES ANSI Y14.5-1982 W.P.S. 1:1-1.4-100 STD. TOLERANCES X.X ± .060 X.XX ± .030 X.XXX ± .010 FRAC. DIM. ± 1/32 DEG. ± 1°	TITLE XTS DOUBLE PLOW			NOTICE: THIS DOCUMENT AND ITS CONTENTS ARE THE PROPERTY OF BURCHLAND MFG. LLC. NO USE OR COPIES MAY BE MADE WITHOUT WRITTEN PERMISSION FROM BURCHLAND MFG. LLC.		
					DRAWING NUMBER DOUBLE PLOW 3			BURCHLAND MFG.			
					DESIGN BY: AB			DATE: 10/22/2012			
REV	CHANGE NUMBER	CHANGE DESCRIPTION	CHANGE BY	DATE							

**BURCHLAND**

3311 Yates Avenue  
Gilman, IA 50106  
641-498-2063  
www.Burchlandmfg.com

